

ANSICHT "A" / VIEW "A"

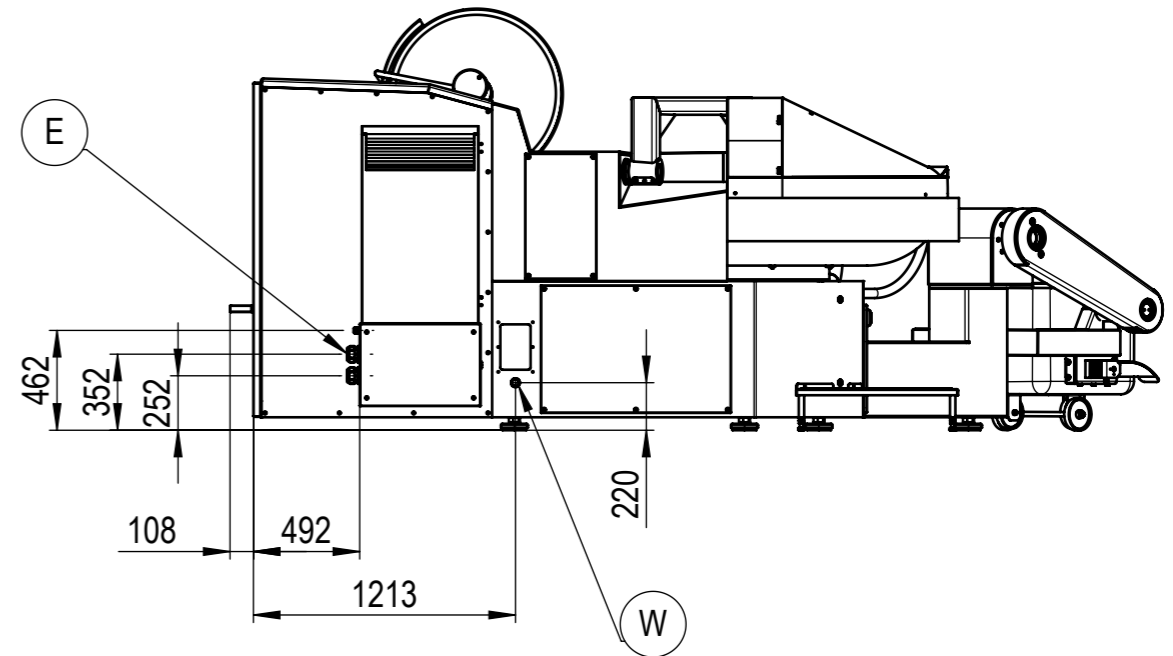

DIMENSION SHEET

name: Kutter / Cutter		type: K500 N AC - KU(X)		customer / country: - / -	
information: Schaltschrank intern / inside cabinet - Auswerfer Rechts / ejector right - Standard / standard - mit Hydraulischer Beschickung / with hydraulic loading hoist - ohne Kühlung / without cooling		machine number: -		SEZ / NAR: -	
Maschinenfabrik LASKA Gesellschaft m.b.H. Makartstraße 60, 4050 Traun - Austria T +43 7229 / 606-0 laska@laska.at		first-angle projection 		model: K0504 / 80000	
This drawing is confidential and must not be disclosed to third parties, reproduced or used or content thereon copied or reproduced without our written consent		all dimensions in mm do not scale this dwg		drawn: hall	
		sheet: 1 / 2		scale: 1:35	
		drawing number: K0504-00001			

Technische Daten / technical data

Schüsselinhalt	bowl volume	[ltr]	500
----------------	-------------	-------	-----

Abmessungen / dimensions

Abmessungen Maschine	dimensions machine	[mm]	4320 x 3310 x 1960
Verpackung Seekiste	seaworthy case	[mm]	4480 x 2300 x 2400
Einbringmaße H x B	minimal height and width for transport h x w	[mm]	1960 x 2000
Mindestraumhöhe	minimum ceiling height	[mm]	2750

Gewichte / weights

Netto-Maschine ca.	net-machine approx.	[kg]	5400
Brutto mit Verpackung	gross with packing approx.	[kg]	6150
max. Gewicht pro Maschinenfuß	max. weight per machine foot	[kg]	1850

Elektrische Daten / electrical data AC - 3x400V / 50Hz

Ausführung	model	[-]	KU	KUX
Nennleistung	rated power	[kW]	198	221
Nennstrom	rated current	[A]	435	505
Sicherung träge	fuse	[A]	500	500
Zuleitungsquerschnitt	feed pipe cross section	[mm ²]	240	240

Versorgungsanschlüsse / supply connections



Elektrischer Anschluß	electrical connection	E	-	-
Wasseranschluß ¹	water connection ¹	W	1"	2 - 6 bar

¹ optional / option

DIMENSION SHEET

customer / country:

- / -

name: Kutter / Cutter		type: K500 N AC - KU(X)		machine number: -		SEZ / NAR: -	
information: Schaltschrank intern / inside cabinet - Auswerfer Rechts / ejector right - Standard / standard - mit Hydraulischer Beschickung / with hydraulic loading hoist - ohne Kühlung / without cooling				first-angle projection 		model: K0504 / 80000	
				all dimensions in mm do not scale this dwg		drawn: hall	
Maschinenfabrik LASKA Gesellschaft m.b.H. Makartstraße 60, 4050 Traun - Austria T +43 7229 / 606-0 laska@laska.at				sheet: 2 / 2		scale: 1:1	
This drawing is confidential and must not be disclosed to third parties, reproduced or used or content thereon copied or reproduced without our written consent				drawing number: K0504-00001		 LASKA	